

Z-AXIS LOCKING PLATE SCREW
2.0mm [5/64in] HEX

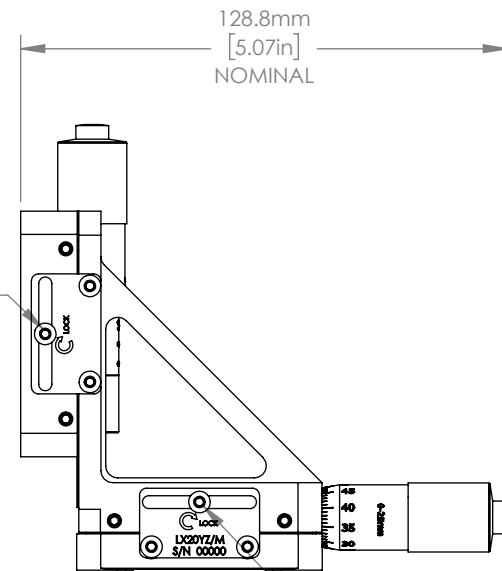

Y-AXIS LOCKING PLATE SCREW
2.0mm [5/64in] HEX

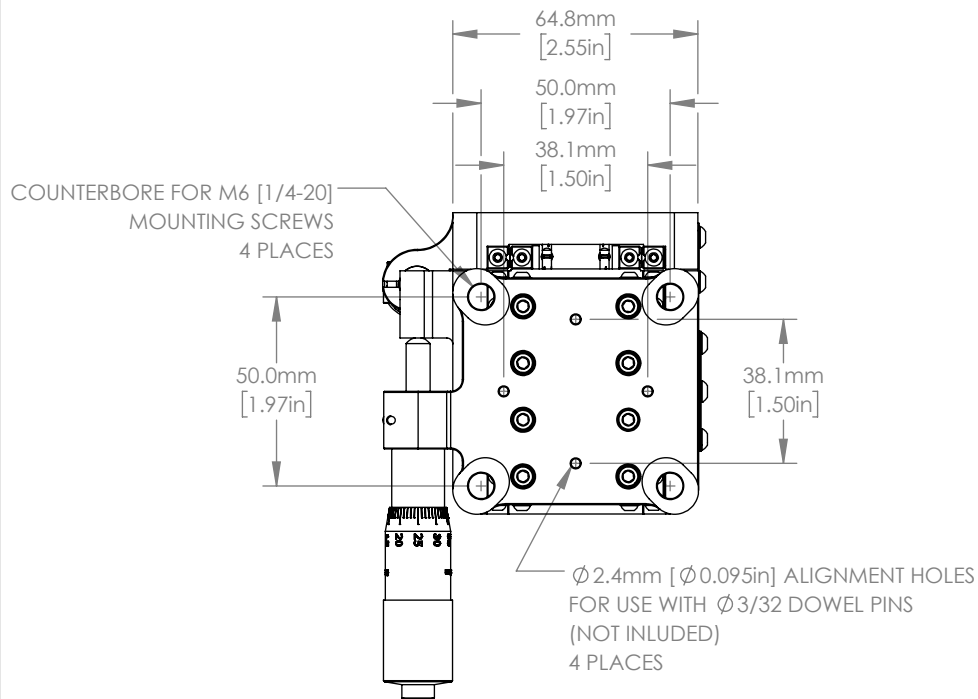
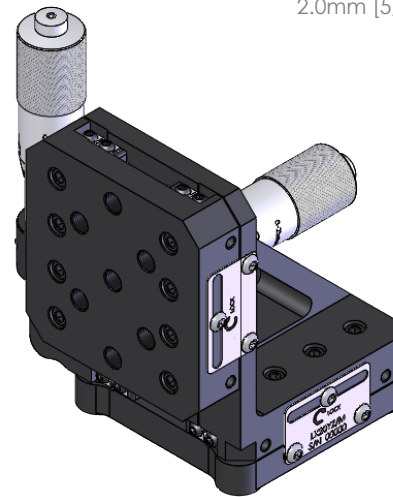

FOR INFORMATION ONLY
NOT FOR MANUFACTURING PURPOSES

DRAWING PROJECTION			THORLABS www.thorlabs.com	
NAME	DATE	METRIC 25mm Y/Z CROSSED ROLLER BEARING STAGE		
DRAWN	MJM	24/OCT/19	MATERIAL	
APPROVAL	CS	25/OCT/19	N/A	
COPYRIGHT © 2019 BY THORLABS			ITEM #	APPROX WEIGHT
VALUES IN PARENTHESIS ARE CALCULATED AND MAY CONTAIN ROUND OFF ERRORS			LX20YZ/M	0.74 kg
			REV	A